

# Sherpa



## USER MANUAL

**Hardware Version:** 90-0038.1  
**Software Version:** v2.15.7-2.2.3

## User Manual Purpose

This manual is designed to guide you in using the Lucid Sherpa Drone for exterior softwashing. Your drone is a tool that can help you clean more efficiently and effectively. You'll learn about the drone's maintenance and care, and how to use it safely. We cannot stress enough the importance of safety when using the drone. As a pilot-in-command, it's your responsibility to ensure a safe operation for every team member involved.

Throughout this manual, you'll learn about drone operations, how to take care of the drone, and how to use it safely. We understand that not everyone is familiar with drone technology, so we've made sure to use simple language that is easy to understand.

## Warranty

### One Year Manufacturer Warranty

The manufacturer warrants this product of any defects in workmanship and materials, under normal residential use and conditions, for a period of one (1) year from the original invoice date. Shipping and handling fees are to be paid for by the customer. Any damages occurring to your item, either on receipt of delivery or as a result of malfunction, will be repaired or replaced by the manufacturer. Lucid Drone Technologies is entitled to investigate the cause of any claimed malfunctions and will grant a replacement or repair at our sole discretion. Any items found to be damaged at the fault of the user will not be covered by this warranty.

Additionally, Return, Warranty, and Insurance coverage services may be offered only when the pilot follows local government regulations for commercial unmanned aircraft. The customer will be responsible for covering all related shipping, handling, packing, and return purchase costs.

This warranty does not include: Any condition resulting from other than ordinary use for which the product was not intended, such as use in rental or contract trade or commercial use; Any condition resulting from incorrect or inadequate maintenance or care; Damage resulting from misuse, abuse, negligence, accidents, or shipping damage; Dissatisfaction due to buyer's remorse; Normal wear and tear; Damage incurred during transportation; Damages incurred during assembly or maintenance; Any used, previously displayed items.

Lucid Drone Technologies makes no express warranty or condition whether written or oral and Lucid Drone Technologies expressly disclaims all warranties and conditions not stated in this limited warranty. To the extent allowed by the local law of jurisdictions outside the United States, Lucid Drone Technologies disclaims all implied warranties or conditions,

To become a certified drone pilot and use the Sherpa drone for cleaning, you'll need to complete our training program. The FAA also requires commercial drone operators to hold a Part 107 license. In this program, you'll learn about drone technology, federal regulations, and how to clean using the drone. We'll also cover the limitations of using the drone for cleaning, as there may be situations where it's not the best solution.

Do not use the Sherpa Drone until you've completed our training program and obtained your FAA Part 107 license. Thank you for choosing Lucid Drone Technologies and the Sherpa Drone. We're excited to help you take your cleaning operations to new heights!

including any implied warranties of merchantability and fitness for a particular purpose. For all transactions occurring in the United States, any implied warranty of condition of merchantability, satisfactory quality, or fitness for a particular purpose is limited to the duration of the express warranty set forth above.

Some states and countries do not allow a limitation on how long an implied warranty lasts or the exclusion of limitation of incidental or consequential damages for consumer products. In such states or countries, some exclusions or limitations of this limited warranty may not apply to the Purchaser.

### Claim Procedures

Claims for defective merchandise must be made within ONE (1) year from invoice date. Claims for missing parts must be made within thirty (30) calendar days after the merchandise is received. Any claim for defective merchandise returns must be packed in original packaging. Photos are required to claim defective merchandise, along with a copy of the original invoice. If the claim is justified, the item(s) or part(s) will be repaired or replaced. It is our policy to replace parts whenever possible. This warranty gives you specific legal rights. You may have other rights, which vary from state to state.

### What Qualifies as a Malfunction

Malfunctions are limited to any technological defect that prevents you from using the drone in its intended use, or any physical defect found on the drone before the first flight. Any preventable damages are not deemed malfunctions as these fall under negligence, and therefore are not covered under the standard warranty. These include, but are not limited to; melting of drone components, corrosion of a component due to lack of maintenance, water or chemical damage resulting from irresponsible or risky operations.

# TABLE OF CONTENTS

<b>User Manual Purpose</b>	<b>2</b>	<b>Remote Controller</b>	<b>12</b>	<b>Window Washing Payload</b>	<b>21</b>
<b>Warranty</b>	<b>2</b>	Remote Controller Diagram	12	Best Practices	21
One Year Manufacturer Warranty	2	Charging the Controller	12	Operating Limitations	22
Claim Procedures	2	Turning Controller On/Off	12	Dilution Ratios	22
What Qualifies as a Malfunction	2	Connecting to the Drone	13	<b>Personnel</b>	<b>23</b>
<b>Overview</b>	<b>4</b>	Controller Settings	13	Pre-Flight Roles and Responsibilities	23
Training Program, System, and Onboarding	4	<b>Pre-Flight Checklist</b>	<b>13</b>	Remote Pilot in Command (RPIC)	23
<b>Safety</b>	<b>4</b>	<b>User Interface</b>	<b>13</b>	Pilot Assistant/Visual Observer (PA/VO)	23
Roles & Responsibilities	4	Android OS	13	Additional Crew	23
On-Site Safety Briefings	4	Controller Volume Settings	13	<b>In-Field Troubleshooting</b>	<b>23</b>
Safety Equipment & PPE	4	WiFi and LTE	13	On-Screen Notifications	23
Securing the Work Area	4	Auterion App	13	On-Screen Messages, Errors, and Notifications	24
<b>RemotelD</b>	<b>5</b>	Vehicle Status Indicators	14	<b>Sherpa Maintenance Guide</b>	<b>25</b>
About RemotelD	5	Fly Tools (Toolbar)	14	Airframe Inspections	25
<b>Operating Limitations</b>	<b>5</b>	Telemetry Panel	14	Drone Body	25
Operational Limitations	5	Battery Status	14	Motor Inspection	25
Operating Environment	5	Video Switcher	14	Propeller Inspection	25
Altitude	5	Camera Controls	15	Lithium Battery Inspection	25
Weather Conditions	5	<b>Flight Modes</b>	<b>15</b>	Wiring Inspection	25
Sustained Winds	5	Position Mode	15	<b>Drone Storage</b>	<b>25</b>
Wind Gusts	5	Altitude Mode	15	<b>Maintenance Schedule</b>	<b>25</b>
Wind Variability and Turbulent Air	6	Land Mode	15	After Each Use	25
Fog and Low Clouds	6	Hold Mode	16	Every Ten Flight Hours	26
Rain	6	Takeoff Mode	16	Every Fifty Flight Hours	26
<b>Drone Systems and Components</b>	<b>7</b>	Return Mode	16	Every One Hundred Flight Hours	26
<b>Overview</b>	<b>7</b>	<b>Lucid Launch</b>	<b>16</b>	One-Year Maintenance	26
Front	7	<b>Drone Flight Operations</b>	<b>16</b>	After Two Years of Ownership	26
Side	7	Pre-Arm Safety Checks	16	Bleach Neutralizer	26
Oblique	7	Arming the Drone	17	<b>Component Spec Sheets</b>	<b>27</b>
Top	7	Controlling Flight	17	Tattu Lipo Battery Guide	27
Spraying Payload	8	Turning Spray On/Off	17	Tattu Plus 1.0 Compact Version	
Window Washing Payload	8	Connecting a Larger Display Screen	17	10000mAh 44.4V 15C 12S1P Lipo Smart	
Motor and Propeller Directions	8	Collision Prevention	18	Battery Pack	27
Folding Propellers	8	<b>Failsafes</b>	<b>19</b>	ISDT X16 Battery Charger	27
<b>Setting Up the Drone</b>	<b>9</b>	Emergency Stop Function	19	DEMA 311.125 Rocket Injector	27
<b>Chemical Compatibility</b>	<b>9</b>	Auto-Disarm	19	SIYI MK15 Controller	27
Strong Acids and Bases	9	Cannot Acquire RTK Fix	19	Auterion Software	27
<b>Lithium Polymer (LiPO) Batteries</b>	<b>9</b>	RC Loss Failsafe	19	Lucid Clear SDS Sheet	27
Battery Safety	9	Flip Detection Auto-Shutoff	19	<b>Customer Success</b>	<b>27</b>
Battery Contact Safety	9	Motor ESC Not Detected	19	Knowledge Base and Helpful Resources	27
Cleaning Battery Contacts	10	Aftermarket Nozzles	20	Request Service or Repair	
Battery Balance Cables	10	Aftermarket Hardware	20	<b>Contact Lucid</b>	<b>27</b>
Permanently Attached Balance Cables	10	Flying with Hose Attached	20		
Removable Balance Cables	10	Hose Clamps	20		
Damaged Balance Cables	10	Compression Fittings	20		
Battery Storage	10	Relieving Hose Pressure	20		
Checking Battery Charge Status	10	Ports on the Underside of Fuselage	20		
Battery Charger Settings	11	Landing Protocols	21		
Low Battery Warnings and Failsafes	11	Landing Procedure	21		
		<b>Transporting the Drone</b>	<b>21</b>		

# Overview

This User Manual was developed in conjunction with our training program. As a Sherpa Drone owner, you will gain exclusive access to the included training portal. The training portal includes all the necessary training to acquire Part 107, teaches you the basics of drones and drone operations and demonstrates how to operate and maintain your Sherpa cleaning drone.



**LUCID RECOMMENDS THAT BEFORE READING THIS USER MANUAL, START YOUR LEARNING PROCESS BY LOGGING INTO THE TRAINING PORTAL.**

## Training Program, System, and Onboarding

Our program is designed to help pilots earn their Part 107 certification, learn drone systems, and operate and maintain the Sherpa Drone with confidence.

In this User Manual, you will find information that parallels our training program, ensuring a seamless experience for all pilots. And for those in the field, we've provided printouts of the manual to aid in your operations.

As part of our training program, we provide resources to help fellow pilots in the field, including pre-flight checklists, workflow guides, and more.

## Safety

### Roles & Responsibilities

The Remote Pilot in Command (RPIC) bears ultimate responsibility for operations. According to FAA regulations, the pilot in command is ultimately responsible for the safety of the operation and the crew.

When taking flight with the Sherpa drone, pilots should conform to all applicable FAA Part 107 regulations as well as state and/or local rules and regulations.

### On-Site Safety Briefings

The pilot in command is required to conduct a safety briefing prior to every flight. The FAA states that the safety briefing should address the following:

1. Define designated areas for take-off and landing
2. Define area of flight operations
3. Define how pilot and VO will ensure bystanders do not enter take-off and landing area(s)
4. Pilot should define and communicate emergency landing areas to all Crew
  - a. If an emergency scenario is encountered, how will the RPIC respond to ensure the safety of the Crew and/or non-involved personnel?

- b. Where is the alternative landing location?
  - c. Communication protocols if an in-flight emergency is encountered
5. Pilot should be aware of the following operational conditions:
- a. Weather, b. Airspace, c. KP Index
  - d. FI or EMI (Interference to the radio, i.e., Wi-Fi dense environments
    - i. Operational protocol if communications cease with drone
6. Pilot should notate local point of contact, showcase goal and deliverables of flight mission, operating environment and obstacles
7. Pilot and crew should be aware of the location of nearest hospital. All Crew should be supplied with local emergency contact information
8. Pilot and Crew should all be aware of safety risks and mitigation measures required for the specific chemical and/or cleaning solution required for operation in the event of emergency
9. Pilot should notate minimum safe distances of 30ft. from aircraft and identify person(s) responsible for keeping bystanders and crew members clear of the area of operation



**NO PERSON SHOULD APPROACH THE DRONE WHILE PROPELLERS ARE SPINNING AND/OR ATTEMPT TO MANUALLY ARREST THE MOTOR.**



**IN THE EVENT THAT THE RPIC DETERMINES FLIGHT OPERATIONS HAVE BECOME UNSAFE, ALWAYS USE THE EMERGENCY STOP FUNCTION TO TERMINATE FLIGHT INTO THE SECURED AREA BELOW.**

### Safety Equipment & PPE

Lucid recommends that all pilots and crew be easily identifiable during aerial operations. Pilots should wear the following personal protective equipment (PPE) during operations:

1. High-visibility vest
2. Hardhat
3. Eye protection
4. Chemical-resistant gloves (when handling chemicals)
5. Chemical-resistant boots

Additional Safety Equipment:

1. Portable eye-wash station
2. Class D Fire Extinguisher in case of battery fire
3. First aid kit including a trauma kit for lacerations

Additional Recommendations:

1. Pilot and VO or pilot assistant should have a hands-free means of communication.
2. Pilot and VO or pilot assistant should identify any potential areas for a hose snag and avoid them to avoid crash. VO or pilot assistant should have a plan to prevent hose snags

### WITHOUT STANDING DIRECTLY BELOW THE DRONE!

3. Lucid recommends bringing a change of clothes in the event an operator's clothing becomes saturated with chemicals.



**NEVER CONTINUE TO WEAR CLOTHING THAT HAS BECOME SATURATED WITH CHEMICALS. SERIOUS INJURY WILL RESULT.**

## Securing the Work Area

It is the responsibility of the RPIC to secure the work area to prevent pedestrians, vehicles or other traffic from entering the work area below and surrounding drone operations. Each project location is unique and may require different methods to secure the work area. In general, the following safety measures are necessary for most operations:

1. Use cones, tape, or other materials to clearly define the work area and/or prevent pedestrians from entering
2. Request permits for road closures as-needed to prevent vehicle traffic in the working area
3. Lock doors and/or block doorways to prevent pedestrians from exiting a building within the work area
4. Place signage around the work area to inform curious onlookers that the RPIC should not be disturbed during flight operations
5. Define a secure takeoff and landing zone



**NEVER OPERATE THE DRONE OVER NON-INVOLVED PERSONS. ALWAYS SECURE THE WORK AREA TO PREVENT PEDESTRIAN OR VEHICLE TRAFFIC FROM ENTERING THE WORK AREA**



**NO PERSON SHOULD STAND WITHIN 30FT OF THE DRONE OR APPROACH THE DRONE AT ANY TIME DURING OPERATION**



**NEVER ATTEMPT TO MANUALLY RESTRAIN THE DRONE OR OTHERWISE CONTROL THE MOVEMENT OF THE DRONE USING THE HOSE**

## RemotelD

RemotelD is often referred to as a "digital license plate" for drones. It provides identification of drones in flight as well as the location of their ground control stations, providing crucial information to ensure public safety as drones become integrated into National Airspace.

The Lucid Sherpa is equipped with RemotelD broadcast capabilities.

### About RemotelD

- RemotelD cannot be turned off at any time by the operator due to FAA regulations
- Any attempt to modify the drone or transmitting equipment in a way that compromises RemotelD capabilities could lead to product failure
- Tampering with or modifying a drone in a manner that disables or limits the functionality of RemotelD broadcast capabilities is prohibited by the FAA



**ALL OPERATORS FLYING IN FAA-REGULATED AIRSPACE ARE REQUIRED TO ADHERE TO REMOTEID REQUIREMENTS ON OR BEFORE SEPTEMBER 13, 2023.**

## Operating Limitations



**OPERATING THE SHERPA DRONE OUTSIDE OF FAA REGULATIONS AND IN A MANNER OTHER THAN DESCRIBED IN THIS MANUAL IS UNSAFE AND COULD LEAD TO CATASTROPHIC FAILURE.**

### Operational Limitations

1. Any drone should not be operated within 30ft of any person or crew member
2. The takeoff and landing area should be clearly defined with cones and high-visibility tape in a manner that makes its presence obvious to non-involved personnel.
3. The Drone should never be operated above people
4. The flight area, in addition to the takeoff area, be cordoned off to eliminate foot traffic at all times. Under no circumstance should persons be below the drone.
5. Pilot should **ALWAYS** notify and communicate to crew and non-involved personnel (bystanders) that drone operations are in progress
  - a. Lucid recommends posting the following sign: "Aerial Cleaning Operations in Progress, Please Stay Clear of the Drone and Pilot"

### Operating Environment

1. The Lucid Sherpa is not equipped to fly indoors or in areas without an open and clear view of the sky (i.e. covered atriums, below overpasses/bridges, indoors, between buildings closer than 30 feet apart, etc.).
2. Note that flight within close proximity to strong sources of radio frequency (RF) interference may cause unexpected flight behaviors (i.e Radio towers, 5G towers, etc.).
3. Keep the drone 30ft from metal objects or sources with magnetic properties during takeoff (i.e. automobiles, steel beams, etc.).
4. Never operate the drone less than 10ft above the ground continuously unless conducting a takeoff or landing.

### Altitude

The FAA mandates that under Part 107, drones cannot exceed 55lbs without additional waivers granted

### Weather Conditions

#### Sustained Winds

The Lucid Sherpa should not be operated in sustained winds exceeding 15mph. Higher wind speeds for sustained periods can affect the safety and stability of the aircraft and may cause chemical overspray onto unintended surfaces.

#### Wind Gusts

Wind gusts may be encountered during typical operations.

Lucid strongly advises against conducting cleaning operations during abnormally windy conditions. The Lucid Sherpa is designed to operate in 15mph sustained winds and wind gusts up to 20mph and can maintain stability in "Position" flight mode without operator input under these conditions.

In the presence of wind gusts and while in "Position" flight mode, the Lucid Sherpa is engineered to withstand deviation from its current, static position within +/- 3ft on the X/Y axis. Onboard sensors measure its position on a millisecond basis to maintain position within inches throughout all flights, unless the RPIC commands the drone to move to a different position.

For example, if the drone is hovering 10ft from a structure for the entirety of the flight and the operator does not provide any input while in position mode, the drone should never collide with a structure in the presence of 15mph winds and/or 20mph wind gusts when operating >10ft from a structure.

The RPIC is responsible for maintaining a safe collision prevention distance of 10ft from a structure while cleaning, resulting in a 3X (+) factor of safety.

See "Collision Prevention" for more information on safe operating distance.

### Wind Variability and Turbulent Air

Certain architectural features and other elements of building design often cause wind/airflow to behave erratically. Always avoid these areas on windy days.

Examples of areas likely to experience turbulent/erratic airflow:

1. Ledges and rooflines
2. Narrow corridors in urban canyons
3. Edges and corners of buildings
4. Dormer windows
5. Spires and pyramidal architectural features

The below image illustrates how air flows over roofs with varying pitches. Areas of unstable air are indicated in blue and should be avoided.



**USE EXTREME CAUTION WHEN FLYING ON WINDY DAYS AROUND ARCHITECTURAL FEATURES SIMILAR TO THE EXAMPLES PROVIDED IN THIS SECTION. TURBULENT AIR CAUSES INSTABILITY FOR ALL AIRCRAFT TYPES, INCLUDING DRONES.**

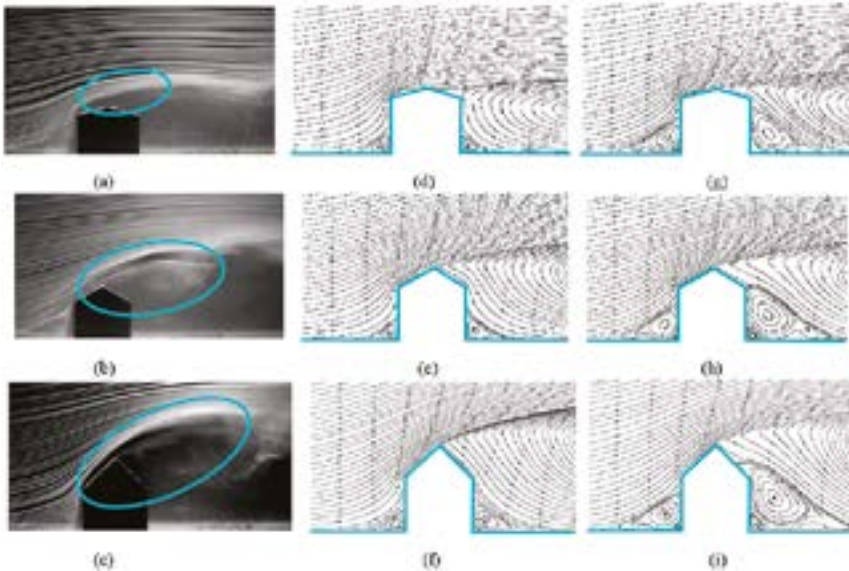

### Fog and Low Clouds

The Lucid Sherpa Drone should not be flown in the presence of fog. Fog creates numerous visibility issues and creates an unsafe flying environment. FAA regulations state that drone pilots must maintain a 500ft distance below clouds or a 2,000ft lateral distance from clouds. Pilots must maintain line of sight with the drone at all times under Part 107.

### Rain

Do not conduct cleaning operations during inclement weather. Light to moderate rain is acceptable for short periods. Lucid recommends planning projects around inclement weather.

# Drone Systems and Components Overview

Front

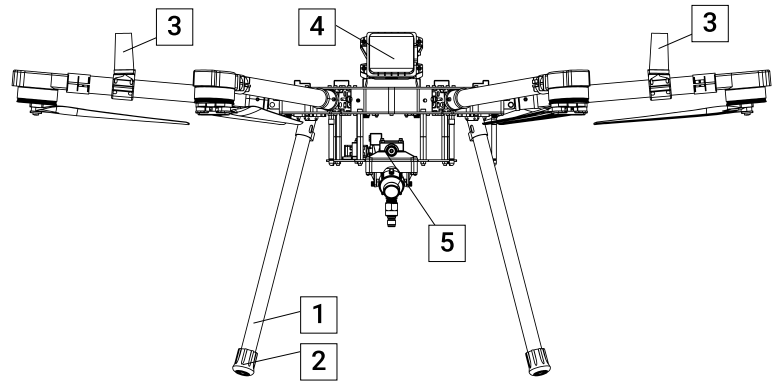

- 1** Landing Gear Leg
- 2** Landing Gear Boot
- 3** GNSS Antenna
- 4** Radar Collision Prevention
- 5** Spraying Payload

Side

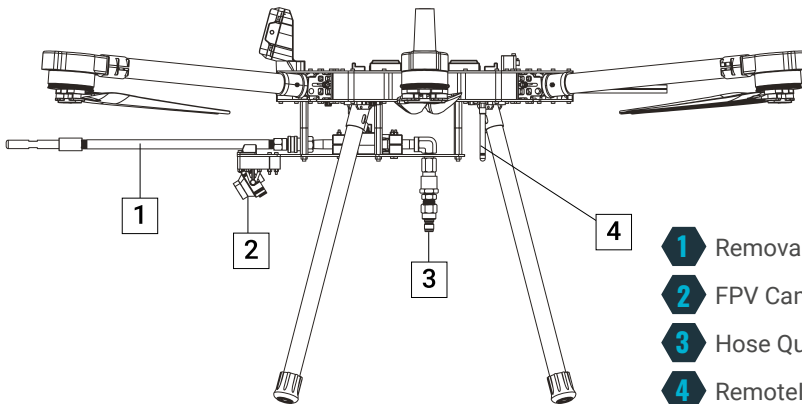

- 1** Removable Nozzle
- 2** FPV Camera
- 3** Hose Quick Connect
- 4** RemotelD Antenna

Oblique

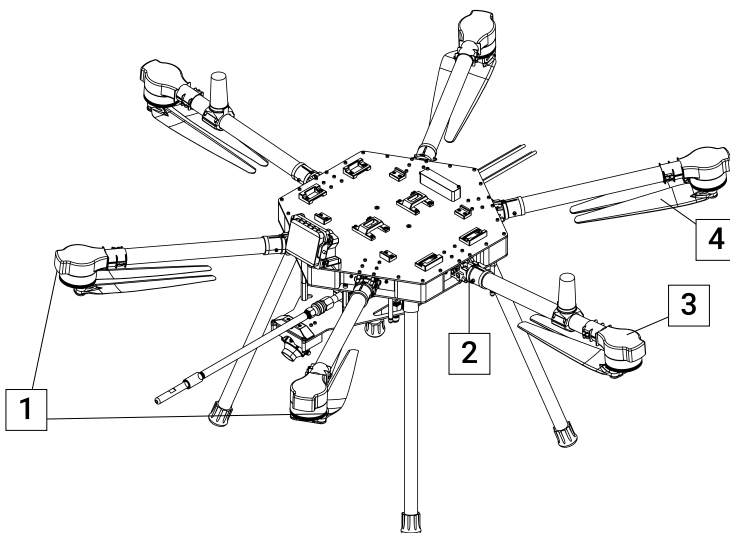

- 1** Anti-Collision Lights (6x)
- 2** Locking Arm Hinge (6x)
- 3** Brushless Motors (3x CW) (3x CCW)
- 4** Folding Carbon Fiber Composite Propeller (3x CW) (3x CCW)

Top

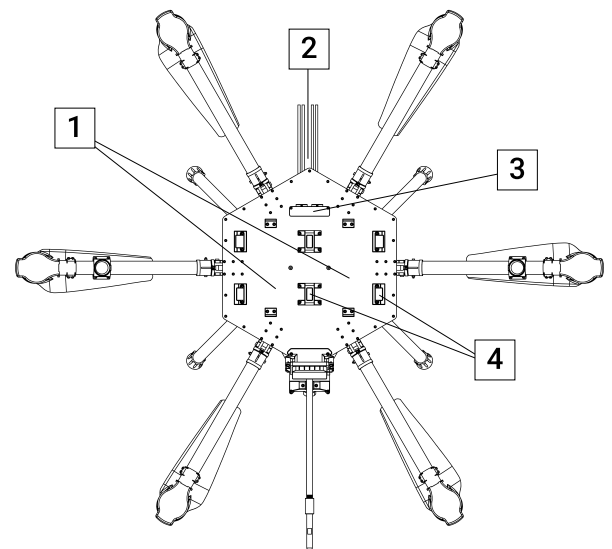

- 1** Battery Trays
- 2** Battery Power Leads
- 3** Balance Cable Protector Port (Dummy Plug)
- 4** Battery Bumpers

## Spraying Payload

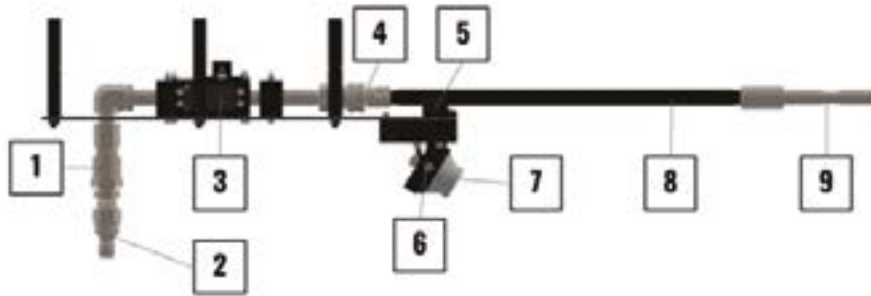

- 1 Swivel
- 2 Hose Quick Connect
- 3 Servo-Actuated Ball Valve
- 4 Nozzle Quick Connect
- 5 Nozzle Rest
- 6 FPV Camera Bracket
- 7 FPV Camera
- 8 Nozzle Shaft
- 9 Assassin Tip

## Window Washing Payload

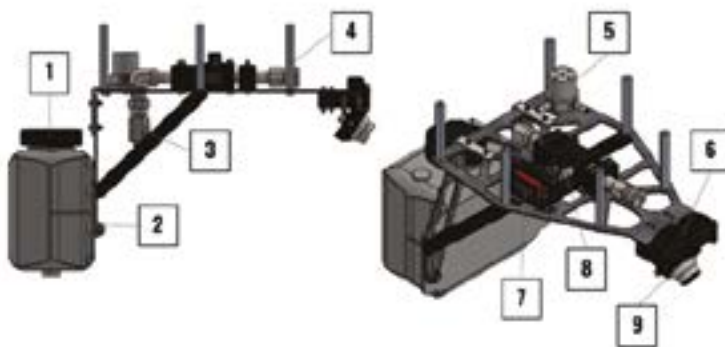

- 1 Tank Cap
- 2 0.5 gal Tank
- 3 Injector
- 4 Nozzle Quick Release
- 5 Injector Valve
- 6 Nozzle Rest
- 7 Servo
- 8 Ball Valve
- 9 FPV Camera

## Motor and Propeller Directions

To maintain stable flight, each motor on a multirotor drone rotates in the opposite direction of its neighboring motors. 3 motors spin clockwise and 3 motors spin counterclockwise. Propellers must match the rotational direction of the motor to which they are mounted.

"CW" = Clockwise  
"CCW" = Counter Clockwise



**IF THE WRONG PROPELLER IS INSTALLED ON THE WRONG MOTOR, THE DRONE WILL IMMEDIATELY FLIP AND CRASH ON TAKEOFF.**

The motors on the Lucid Sherpa are inverted (upside down) to reduce vibration. This means that standard propellers purchased online (sold by non-Lucid vendors) are not compatible with the inverted motors. Please contact Lucid for replacement propellers to ensure you receive the correct replacement part, or if you have any additional questions about replacing propellers.



**THE PRINTED DIRECTION ON THE MOTOR'S ROTOR WILL BE OPPOSITE OF THE DIRECTIONAL MARKINGS ON THE PROPELLER.**

Mount **INVERTED CW Propellers on CCW Motors**  
Mount **INVERTED CCW Propellers on CW Motors**

## Folding Propellers



It is important that the two (2x) bolts (circled in blue) securing the propellers to the folding propeller bracket do not restrict the propellers from opening during flight. If the bolts are too tight on one or more propeller brackets, excessive vibrations may cause degradation of flight performance and/or lead to drone instability. Each propeller should be easy to unfold by hand, but not so loose that the propeller can freely move with no resistance at all. Temporary (non-permanent) thread locker should be used on all motor bolts after a propeller is replaced.

The four (4x) bolts (shown in green) securing the propeller bracket to the motor should be tight and secure. The above section is NOT referencing the four (4) bolts shown in green that secure the propeller bracket to the rotor. The bolts in green must be tight.

# Setting Up the Drone

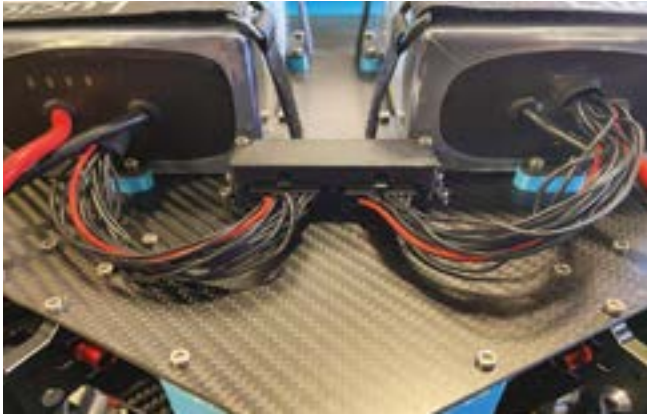

1. Unfold the arms until the latch “clicks” to lock the arm in place.
2. Remove the foam propeller guards and store inside the case.
3. Unfold each propeller to make sure all propellers are spread evenly throughout.
  - a. Failure to completely unfold the propellers before take off will result in premature propeller wear and could result in the propellers getting stuck folded, causing the drone to flip.
4. Install the hose with the provided quick connect fitting.
5. Install the nozzle with provided quick connect fitting.
6. Install the batteries with the power cables facing the rear of the drone. Ensure the batteries are fully seated on the drone between the battery bumpers.
7. Secure the batteries in place using the velcro straps.
8. Plug in the balance cable connectors to the balance cable protector ports.
  - a. **Note:** Some batteries have removable balance cables. If the cables are removable, this step is not required. Removable balance cables should be removed before flight.
9. Plug in the batteries (Note: Batteries can be connected in any order).
  - a. Connectors **MUST** be fully seated to make sure that the red gasket is no longer visible. This prevents water from entering the connector.
  - b. The plugs are intentionally tight to provide a secure connection.

## Chemical Compatibility

The Lucid Sherpa is designed to be used with sodium hypochlorite (bleach) or Lucid Clear (window cleaning solution). Due to the extensive number of available cleaning chemicals, Lucid does not supply an exhaustive list of compatible chemicals. Instead, Lucid recommends checking chemical compatibility with the following material types before using any other type of cleaning solution. Incompatible chemicals may cause seals or components to dissolve, degrade or otherwise result in irreversible damage to the drone.

1. ABS plastic
2. 316 stainless steel and 304 stainless steel
3. Carbon Fiber
4. Anodized Aluminum
5. EPDM rubber
6. Silicone

If you wish to use alternative chemical types and are unsure of compatibility, please contact Lucid to discuss and review the proposed use-case in more detail.



**WARNING: NEVER MIX CHEMICALS UNLESS YOU ARE CERTAIN OF COMPATIBILITY.**

## Strong Acids and Bases

Lucid does not recommend using strong acids or strong bases with the Lucid Sherpa. For example, hydrochloric acid will dramatically accelerate corrosion and the degradation of many components on the airframe.

## Lithium Polymer (LiPO) Batteries

### Battery Safety

LiPO Batteries are to be treated with extreme care. Lucid Drone Technologies does not manufacture batteries. Always adhere to manufacturer-supplied documentation.

[Detailed battery information can be found here.](#)

- Always use Lucid-supplied batteries
- Always fly with two (2) batteries
- Always use batteries with equivalent charge level. For example, do not use one battery at 100% capacity and the other at 25% capacity
- Use of third-party batteries may lead to inaccurate battery level readings and could result in a crash

### Battery Contact Safety

Battery contacts are prone to corrosion over time and should be monitored for any signs of corrosion buildup. Even minor corrosion buildup can result in a poor electrical connection. When an electrical connection is inhibited by corrosion, debris or any other material, excessive heat is produced that could lead to a fire.

When not in use, do not leave batteries onsite where they could be exposed to chemicals or overspray that could accelerate corrosion inside the contacts.

**Note:** Batteries that are commonly used in coastal environments where salt air is present may experience corrosion buildup faster than batteries used in other operating environments. Always store batteries in LiPO safe bags when not in use to prevent corrosion buildup.

## Cleaning Battery Contacts

During scheduled maintenance or daily operations, if you notice that corrosion is present on the battery contacts, clean them with a round wire brush. The bristles of the wire brush should match the inner diameter of the battery contacts. Use DeoxIT Cleaner with the wire brush to remove corrosion.



**WARNING: WHEN CLEANING BATTERY CONTACTS, USE CAUTION TO ENSURE THAT BOTH BATTERY CONTACTS NEVER CONTACT A CONDUCTIVE MATERIAL SUCH AS THE WIRE BRUSH AT THE SAME TIME TO AVOID CREATING A SHORT CIRCUIT. BRIDGING CONTACTS CAN LEAD TO PRODUCT DAMAGE AND/OR INJURY FROM ELECTRICAL SHOCK.**

## Battery Balance Cables

Battery balance cables play important in LiPO battery charging because they enable the charger to do two things:

1. Monitor each cell during charging for abnormal or faulty conditions
2. "Balance" each cell within the battery to ensure that all cells are charged evenly

Battery balance cables may be permanently attached to the battery or may be removable, depending on the availability of the batteries supplied at the time of your purchase.

## Permanently Attached Balance Cables

When using batteries with permanently attached balance cables, insert the balance cable connector into the balance cable protector port (dummy port) towards the rear of the drone during flight operations. The dummy port is intended to protect the balance cable connector contacts from chemical exposure and corrosion during flight.



## Removable Balance Cables

When using batteries with removable balance cables, remove the balance cables and store them in a protected area during flight operations. The balance cables are not needed for flight. After removing the balance cables from the batteries, replace the rubber cover that protects the battery balance cable port before installing batteries on the drone. This cover protects the port from liquid exposure, chemical exposure, and corrosion during flight.



## Damaged Balance Cables

Take extreme care not to damage battery balance cables. This is especially important when using batteries with permanently attached balance cables. Damaged balance cables or connectors could lead to battery damage or fire during charging and/or prevent a battery from charging if the charger determines the cable or connection is faulty.



**IF REMOVABLE BALANCE CABLES BECOME DAMAGED, PLEASE CONTACT LUCID FOR REPLACEMENT. DO NOT ATTEMPT TO REPAIR DAMAGED BALANCE CABLES. DO NOT ATTEMPT TO CHARGE BATTERIES WITH DAMAGED BALANCE CABLES.**



**THE PRINTED DIRECTION ON THE MOTOR'S ROTOR WILL BE OPPOSITE OF THE DIRECTIONAL MARKINGS ON THE PROPELLER.**

## Battery Storage

When batteries are not in use, they should be stored as follows:

1. Store in LIPO safe bags to prevent fires
2. Store in temperatures between 40 and 80 degrees Fahrenheit
3. Never store in direct sunlight for extended periods when not in use

## Checking Battery Charge Status

To check the charge status of the batteries, tap the button on top of the battery once. The battery level indicator is a series of four (4) illuminated bars which represent the percentage capacity remaining.

Remaining Power	LED 1	LED 2	LED 3	LED 4
0%~12%	Blink	off	off	off
13%~24%	on	off	off	off
25%~37%	on	Blink	off	off
38%~49%	on	on	off	off
50%~62%	on	on	Blink	off
63%~74%	on	on	on	off
75%~94%	on	on	on	Blink
95%~100%	on	on	on	on

**Disclaimer:** The LED indicators are intended to be a general representation of capacity remaining. Always fly with fully charged batteries. Always check on-screen for a more accurate reading of capacity remaining.

## Battery Charger Settings



**WARNING: NEVER ATTEMPT TO CHARGE LIPO BATTERIES AT HIGHER CURRENT RATING (AMPS) THAN THE RECOMMENDED SETTINGS IN AN ATTEMPT TO EXPEDITE CHARGING. EXCESSIVE CHARGING CURRENT WILL PERMANENTLY DAMAGE BATTERIES.**

- **Charger Settings:**

- › Chemistry: LIPO
- › Cells: 12S
- › Full Cell Voltage: 4.2V
- › Current: 16A

- **How to Charge Batteries**

- › Connect the black balance cable plug to the charger
- › Fully insert the yellow plug into the charging port
- › Follow on-screen instructions to begin charging



**BATTERIES SHOULD BE KEPT AWAY FROM FIRE-HAZARDS. DO NOT LEAVE BATTERIES UNATTENDED WHILE CHARGING.**



**BATTERIES SHOULD BE HANDLED WITH EXTREME CARE. DAMAGED BATTERIES (I.E. DENTS, PUNCTURES, BROKEN PROTECTIVE SHIELD, PUFFED, ETC.) SHOULD NOT BE USED AND SHOULD BE REPLACED IMMEDIATELY.**



**DO NOT SHIP BATTERIES VIA AIR, PER FAA REGULATIONS. WHEN TRAVELING VIA PLANE, DO NOT CHECK YOUR BATTERIES BELOW THE PLANE. BATTERIES MUST BE CARRIED ONBOARD THE AIRCRAFT.**



**NEVER CHANGE CHARGER SETTINGS WHILE CHARGING. ALWAYS WAIT FOR BATTERIES TO COMPLETE A CHARGING CYCLE BEFORE CHANGING SETTINGS.**



**NEVER CHARGE BATTERIES IN DIRECT SUNLIGHT.**

For more information about charger settings and charger user interface, please reference documentation supplied by the manufacturer of the charger.

## Low Battery Warnings and Failsafes

Lucid values safety above all else and has built in features to make sure you're getting the highest amount of flight time without exceeding the batteries abilities. When the drone batteries are getting low, It's time to land safely and replace them with fully charged batteries to maximize efficiency.

**Note:** Flying higher and lifting more hose weight will deplete batteries faster than when flying lower and lifting less hose weight.

The Lucid Sherpa provides pilots with three (3) layers of low-battery notifications. These features are designed to give operators ample notice to conduct a safe landing.

### 5% Capacity Remaining: Low Battery Warning

- Warning message will display on-screen
- Pilot should begin returning to land at this time

### 7% Capacity Remaining: Critical Battery Failsafe

- Warning message will display on-screen
- The drone will conduct a forced landing. Pilots may resume control to manually land drone in the desired location by moving one or more joysticks in any direction.

### 5% Capacity Remaining: Emergency Battery Failsafe

- Emergency message will display on-screen
- The drone will conduct a forced landing. Pilot will be UNABLE to control the drone as it lands. Any obstacles under the drone will not be avoided as the drone attempts to conduct an emergency landing
- Under no circumstance should pilots rely on emergency failsafes during normal operation
- The emergency battery failsafe is only intended to function as a last line of defense to minimize property damage resulting from negligent operations

Refer to User Interface -> Battery Status in this manual for more information

# Remote Controller

The Sherpa cleaning drone comes with an MK15 remote controller. The remote control comes with a built-in tablet displaying flight-necessary information in real time. During the flight, pilots are informed of their altitude, heading, distance, GPS data, camera view, and current battery status.

The controller will be in a case that would include the following:

1. Remote Controller
2. USB-C Wall Charger
3. USB-C Charging Cords



**ALWAYS STORE AND TRANSPORT THE CONTROLLER IN THE CASE. IGNORING THIS MAY CAUSE PERMANENT DAMAGE TO THE CONTROLLER.**

## Remote Controller Diagram

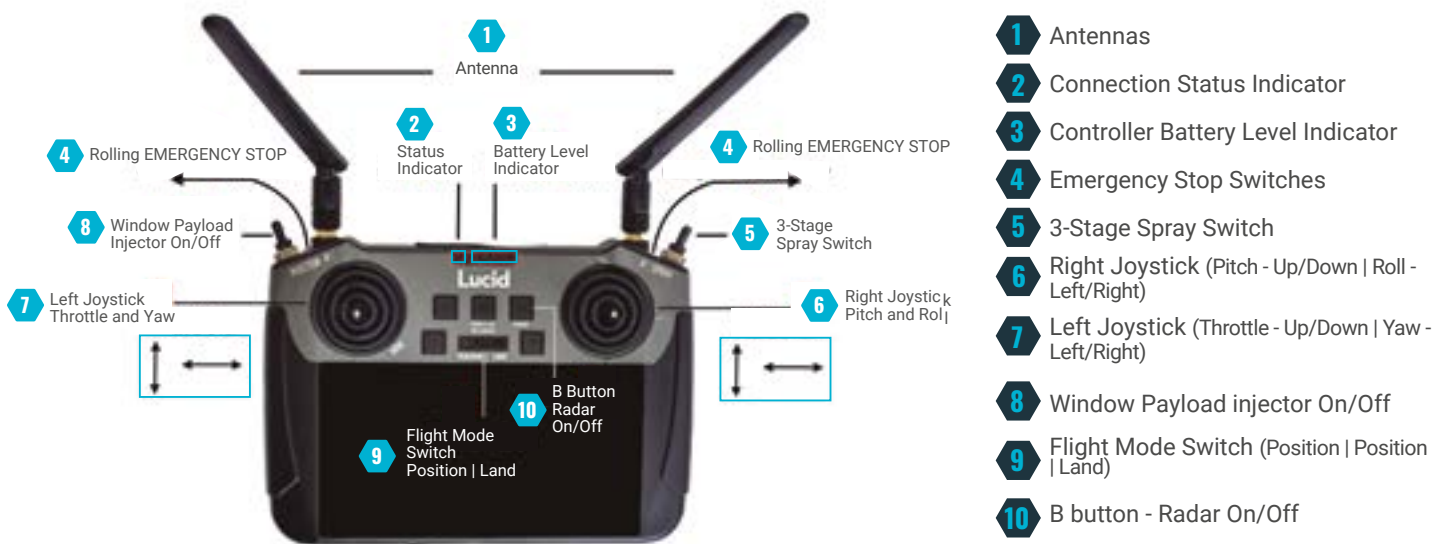

## Charging the Controller

- The controller can **ONLY BE CHARGED** using the supplied cable and power block
  - › **IMPORTANT: Attempting to charge with alternative chargers could make it appear that the controller is being charged, but is not**
- The controller can only be charged when it is turned off
  - › **IMPORTANT: A blank/black screen does not necessarily mean the controller is off; it could be idle/asleep and will not charge while in this state**
- When charging, check that a red light is displayed beside the USB-C charging port on the bottom of the controller
  - › **Red light:** Charging (next to the USB-C port)
  - › **Green Light:** Fully charged OR not charging (next to the USB-C port)

- press and hold the button until all of the blue lights illuminate and you hear the controller play a series of tones
- To turn the controller OFF, press and hold the power button and tap “power off” when the menu pops up (the controller will play a series of tones indicating it has turned off)
- **IMPORTANT: The controller also has a “sleep” function where the screen is not illuminated, but the controller is not off**
  - › If the screen is off but the lights on the power button and on the top of the controller are on, the controller is NOT off and will NOT charge
  - › While in “sleep” mode, the controller will still consume battery
  - › The controller will NOT charge while powered on OR while in sleep mode
- To put the controller to sleep: Tap the power button
- To wake the controller up: Tap the power button again

## Connecting to the Drone

- To turn controller on, tap power button then hold until the lights all go blue
- The controller will automatically connect to the drone once both are powered on
- Connection Status Lights:
  - › **Red:** Not connected



› **Green:** Connected



- It may take up to thirty (30) seconds for the controller and drone to establish a secure connection
- Once the controller has powered on, tap the "Auterion Mission Control" app icon
- Ensure that both antennas are screwed tightly onto the threads and unfolded pointing up

**Troubleshooting:** If for any reason the drone and controller have not connected after one (1) minute, restart both the drone and controller and try again.

## Controller Settings

Never change controller settings unless otherwise instructed to do so by Lucid staff. Any changes to controller settings may cause unexpected, unintended, or undesirable flight behavior that may result in injury or property damage.

Controller settings have been carefully configured to meet the majority of operator needs and preferences. In the event that you feel the default settings do not meet your needs, please contact Lucid Customer Success to discuss your preference/request in more detail.

## Pre-Flight Checklist

- Are the propellers evenly spread?
- Are the controller antennas unfolded?
- Do the motors spin freely?
- Are both batteries fully charged?
- Are all motor lights illuminated?
- Do you have a clear view of the sky?
- Is the drone at least 30ft away from objects?
- Are the nozzle and hose quick-release fittings fully seated and secured?
- Are the balance cables plugged into protector ports?
- Is the drone on level surface?

## User Interface

### Android OS

The Lucid Sherpa controller uses an Android-based operating system. For more information regarding the Android user interface, please refer to Google's online documentation.

### Controller Volume Settings

Volume settings are managed through the Android OS. For more information regarding the Android user interface, please refer to Google's online documentation.

Lucid recommends ensuring that controller volume is set to max volume. Important messages such as low battery warnings are displayed on-screen AND announced from an audible voice.

### WiFi and LTE

The drone is equipped with embedded LTE antennas and will automatically connect to available 4G cellular networks when available. A SIM card comes pre-installed in the drone. Internet connectivity (LTE or WiFi) is not required for operation but is required for remote updates and/or troubleshooting support.

The MK15 controller does not come with a SIM card installed. Without connection to LTE or WiFi, base maps will not be displayed on screen. If operators wish for a base map to be displayed, they may choose to install a SIM card at their discretion. The position of the drone and position of operator will still be displayed accurately, relative to one another. A base map is not required for cleaning operations.

### Auterion App

To interface with your drone using the built-in display screen, get started by tapping on the Auterion app on your home screen.

The drone and controller must both be powered on to display relevant drone information.

## Vehicle Status Indicators

There are several icons at the top of the screen that provide helpful information to the RPIC before, during, and after flight operations.

### Vehicle Status Indicators (Top Bar)



The top bar is used to monitor high-level vehicle state and modes, and to set the current vehicle, mode, and armed state.

Icon	Name	Description
	Menu / Icon	App menu (transitions to Fly, Plan, Vehicle Setup, Flight, User Login, Application Settings).
	High-Level Status / Vehicle Selector	High-level status of the current vehicle (color and status description). Also used to select the current vehicle.
	Mode	Display the current flight mode. Select to enable a manual flight mode.
	Armed/Disarmed State	Display select the armed state. The states are <b>Armed</b> (motors spinning), <b>Disarmed</b> (motors stopped), <b>Emergency Stop</b> (motors stopped in flight, potentially saving the drone to crash).
	Collision/Avoidance System Status	Indicates that the collision/avoidance system is ready to protect the vehicle (green) or not (red).
	Parking	Parking status.
	RC Status	Position Mode POI. Set/Reset/Unset: if defined, the icon can be pinched to remove the existing position mode POI.
	RC Status	Remote control RC2 status.
	GPS Status	GPS count, lock, HDOP, VDOP, course over ground. <div style="border: 1px solid black; padding: 5px; width: fit-content;"> <p>GPS Status</p> <p>GPS Count: 10</p> <p>GPS Lock: 30 lock</p> <p>HDOP: 6.8</p> <p>VDOP: 8.0</p> <p>Course Over Ground: 0.0</p> </div>

## Fly Tools (Toolbar)

The fly tools on the left side of the screen provide operators with the ability to conduct an automated takeoff. Only "Takeoff" and "Land" functions are supported at this time.

### Fly Tools

The fly toolbar is used to execute most flight and preflight operations. The toolbar only displays valid buttons for the current vehicle's state (valid options are highlighted in green).

Icon	Name	Description
	Fly	Switch to Fly Mode (order to plan a mission, perform a takeoff).
	Checklist	View and edit mission checklist.
	Takeoff	Arm vehicle and takeoff (option visible if landed).
	Land	Land vehicle and disarm (option visible if flying).
	Return	Fly to a safe point. The performing behavior depends on vehicle configuration.
	Pause	Pause current operation.
	Action	Displays additional actions for current vehicle state. May be used to start, pause, or stop missions, etc.

## Telemetry Panel

The telemetry panel displays important information such as heading, altitude, and total flight time.



## Battery Status

The user interface provides operators with two icons that represent the charge status of the batteries onboard the drone (small drone icon) and the charge status of the controller (small controller icon). Tapping on the drone battery status icon will display more detailed battery usage information in a pop-up window.



## Video Switcher

The video switcher toggles between the FPV camera view and the (unpopulated) base map view. Tap within the window in the bottom left of the screen to toggle between each view.

### Video Switcher

The video switcher in the bottom left of the map displays video feed from a connected camera. Select anywhere in the window to toggle the video full screen (the map appears in the switcher).



The switcher is only visible if enabled in the Application Settings. Several other UI features are only available if the video is displayed full screen (e.g. camera controls).

The switcher can be resized, minimized or unlinked. Tap/press on the switcher to see the options.



	Updown	Updown controller stick operation (if supported by OSD)
	Roll	Roll controller stick operation (if supported)
	Yaw	Yaw controller stick operation
	Pitch	Pitch controller stick operation

## Camera Controls

The Lucid Sherpa is equipped with a waterproof, wide-angle first-person-view (FPV) camera that supplies a live video feed to the operator.

To change the tilt angle of the camera, loosen the thumb screws on each side of the camera bracket, adjust the position, then retighten the thumb screws. To clean the camera lens, use a microfiber cloth to prevent scratching the lens.

Users are unable to retrieve photos or videos at this time.

### Camera & Gimbal Controls

The Camera and gimbal controls are used to capture images or video, change where the camera is pointing, and power output. They also display available memory and provide access to other settings.

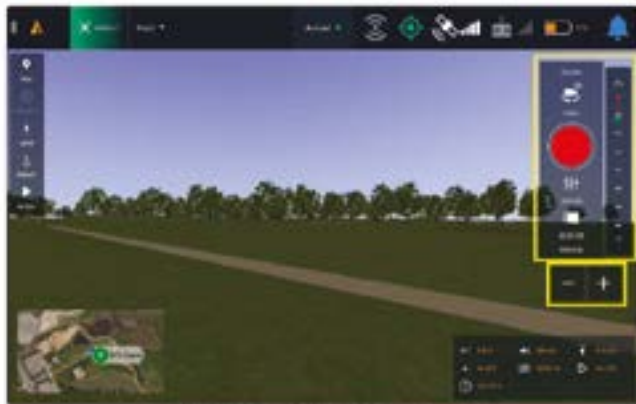

## Flight Modes

[Additional information about Auterion software can be found by clicking this link.](#)

### Position Mode

The primary flight mode for drone flight and general operations.

- Position mode utilizes numerous onboard sensors to provide a stable and easy flight experience. When in

- position mode, the drone will hold its current position and hover until the pilot commands the drone to move using the joysticks. This mode is intended to counteract external forces like gravity, wind, spray pressure and forces exerted by the hose.

### Altitude Mode

Altitude mode uses the known altitude from a barometer to maintain altitude but cannot maintain position: When you center the sticks:

- The drone will maintain altitude, but will continue moving forward with existing momentum until slowed by air resistance, and may drift in response to wind and other forces such as hose tension.



- Under failsafe conditions, the drone may enter Altitude mode.
- Altitude Mode will keep the drone's altitude constant, but the pilot must command pitch and roll manually to counteract any external forces such as wind or hose movement.
- If the drone switches to Altitude Mode, it is recommended that the pilot make a controlled landing as soon as possible. Altitude hold mode is difficult for most pilots to operate and is intended to provide a "last chance" effort for the pilot to land the drone safely.

### Land Mode

Land mode may be used by the pilot at any time to conduct an automated landing. Land mode is also used during some failsafe conditions if the onboard sensors and logic determine that a controlled landing is needed for safety reasons.

- When the drone enters land mode (whether commanded manually or automatically due to a failsafe), the pilot may regain control of the drone at any time by moving the joysticks UNLESS the drone entered land mode due to a low battery failsafe.

› **Note:** The drone will not avoid obstacles while in land mode and will not respond to operator input until landing is complete and/or switched to another flight mode.



**IMPORTANT: If the RPIC ignores the low battery warning and critical battery warning and the battery level reaches an emergency state (5%), the drone will conduct an automated landing that CANNOT be overridden.**

› **Note:** During an emergency battery forced landing, the drone will descend directly downward. The RPIC will not be able to avoid roofs, obstacles, or other obstructions below. To prevent property damage or collision, the RPIC should never allow the battery to reach an emergency state.

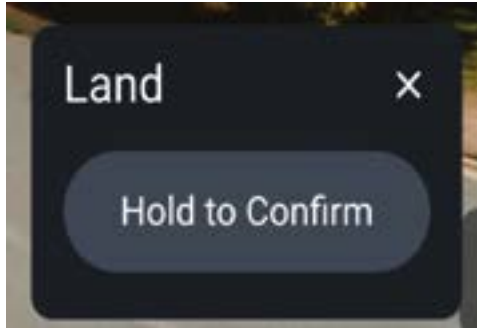

### Hold Mode

Hold Mode is an automatic mode used to hold a vehicle at a particular location.

The drone will enter Hold Mode if RC connection is lost between the controller and drone. The drone will remain in its current position until connection is regained. In the event that connection cannot be regained, the drone will hover in place until it reaches a critical battery level at which point it will conduct an automated landing.

### Takeoff Mode

Takeoff mode initiates the automatic takeoff sequence. The mode can be activated by selecting the Takeoff button ([Fly View Toolbar](#)).

When using this mode the drone will automatically arm, then climb to 2.5m (~8.2ft) above the takeoff location, pause, then hover in place. The drone will remain in this position until it receives stick inputs from the RPIC.

### Return Mode

In the Fly Tools menu on the left side of the screen, users have the ability to command the drone to “return to home”. DO NOT use this function or any of the automated mission functions during cleaning operations. Automated modes such as “Return Mode” do not take into account tethered operations and could lead to hose hangups.



**DO NOT USE AUTOMATED FLIGHT MODES. AUTOMATED MODES DO NOT ACCOUNT FOR OBSTACLES ALONG THE FLIGHT PATH AND COULD LEAD TO A COLLISION OR CRASH. COLLISION PREVENTION IS NOT ACTIVE WHILE USING AUTOMATED MODES.**

## Lucid Launch

### Dual GNSS:

Our proprietary shielded board incorporates two U-Blox F9P high-precision GNSS modules, serving as a reliable source of position and highly accurate heading for the drone. By calculating the relative positioning of each antenna, our software determines the drone’s orientation. With shielded wires, a custom aluminum enclosure, and meticulous board design, this can help with interference from cell towers, Wi-Fi routers, and other potential sources doesn’t compromise the strong signal received from satellites.

### Movement Learning:

Our system incorporates three sets of IMUs (Inertial Measurement Units) and powerful algorithms that start monitoring and learning the drone’s movement right after takeoff. In the event of any sensor issues during flight, our software utilizes subtle motion cues to calculate the drone’s heading. To ensure precise measurements, we’ve meticulously designed our platform to reduce vibrations, providing the cleanest data to the flight controller.

### Smart Compass:

Unlike most drones that solely rely on a compass, our smart compass mitigates the risks associated with magnetic interference in urban environments. Traditional compasses can be affected by iron present in building materials and electromagnetic fields generated by onboard electrical currents. We strategically position our compass to minimize interference from invisible magnetic and electromagnetic fields. Moreover, our algorithms are trained to identify subtle heading disturbances caused by electrical current fluctuations. The flight computer anticipates expected electromagnetic interference, distinguishing valid readings from unreliable ones.

### Sensor Selector Software:

Our advanced algorithm constantly monitors each sensor’s readings in real-time, ensuring the most reliable data is used at any given moment. If any discrepancies arise between the sensors, the algorithm determines whether to fuse the readings from multiple sensors to arrive at an “average” value. For instance, when operating in urban canyons with poor GNSS reception, Lucid Launch can help the drone rely on the compass while on the ground and seamlessly switch to the most trustworthy sensor or set of sensors during flight.

## Drone Flight Operations

### Pre-Arm Safety Checks

*Conditions that need to be met for the drone to safely arm and begin operations:*

The Lucid Sherpa performs a series of self-checks before the operator can begin flying. These checks are important to ensure safe operations.

- Right-hand controller joystick must be in “neutral” (center) position when arming
  - › Only the left joystick is used to arm the drone
- Drone is on a relatively flat surface
  - › The drone requires a reasonably flat surface to take off. If the drone detects that it is tilted prior to arming, it will prevent the operator from taking off.
- Sufficient satellite reception for safe operations
  - › The drone requires a clear view of the sky and a solid connection to each of the satellites it can “see”
- Radar doesn't detect nearby objects
- ADD new compass logic while on ground

## Arming the Drone

Land mode may be used by the pilot at any time to conduct an automated landing. Land mode is also used during some failsafe conditions if the onboard sensors and logic determine that a controlled landing is needed for safety reasons

- When arming the drone, the right joystick must be in the middle (neutral) position
- The slider in the middle of the controller must be set to “Position”
  - › Drone will arm if auto take-off is commanded with the slider in the “land” position, but not if arming is commanded using stick positions
- To arm, hold the left joystick in the lower right corner
  - › The controller will say “armed” outloud
  - › “Armed” will display in the status bar
  - › The propellers will begin to spin at an idle speed.
  - › If throttle is not applied after ten (10) seconds, motors will automatically disarm



**IMPORTANT: ALWAYS APPLY FULL THROTTLE THROUGH TAKEOFF. ONCE THE DRONE IS AIRBORNE AND ABOVE HEAD HEIGHT (10FT–15FT), YOU MAY CONTINUE FLYING AND/OR RETURN THE THROTTLE TO THE NEUTRAL POSITION TO MAINTAIN A STABLE HOVER. DO NOT LET THE DRONE HOVER LESS THAN 10 FEET ABOVE THE GROUND FOR EXTENDED PERIODS.**

## Controlling Flight

1. Left Joystick (Controls Yaw and Elevation)
  - a. Pushing stick UP will cause the drone to ASCEND
  - b. Pushing stick DOWN will cause the drone to DESCEND
  - c. Pushing the stick LEFT will turn the drone LEFT (rotate counter-clockwise)
  - d. Pushing the stick RIGHT will turn the drone RIGHT (rotate clockwise)

2. Right Joystick (Controls Pitch and Roll)
  - a. The right stick controls all lateral motion of the drone
  - b. Pushing the stick UP will cause the drone to move FORWARD
  - c. Pushing the stick DOWN will cause the drone to move BACKWARD
  - d. Pushing the stick LEFT will cause a LATERAL MOTION to the LEFT
  - e. Pushing the stick RIGHT will cause a LATERAL MOTION to the RIGHT

### Left Stick

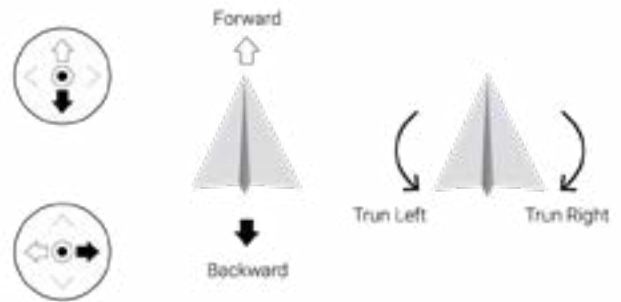

### Right Stick

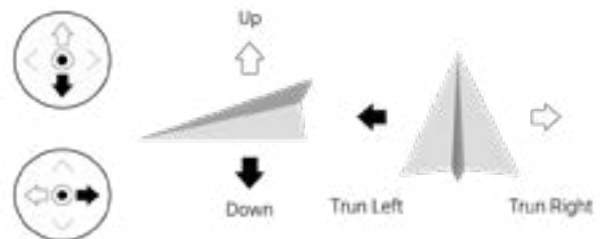

## Turning Spray On/Off

- The spray toggle in the upper-right corner of the controller is a 3-position switch
  - › Towards Operator: OFF
  - › Middle: Low Flow
  - › Away from operator: High Flow

## Connecting a Larger Display Screen

- During demos, it can often be helpful to show others what you are seeing on your controller screen without them needing to look over your shoulder
- To do this, simply connect an HDMI cord to the HDMI port on the top of the controller
- Lucid recommends using a small diameter HDMI cable to reduce weight and limit the chance for damage to the HDMI port during operations

## Collision Prevention

### Radar: Forward-Facing Collision Prevention

The Sherpa comes equipped with a forward-facing radar system that will detect objects and prevent the drone from colliding with objects in the forward direction.

**Radar Field of View (FOV):** The radar can detect obstacles and prevent collision with obstacles within a 43 degree (horizontal) x 30 degree (vertical) detection zone at up to 50m (164ft).

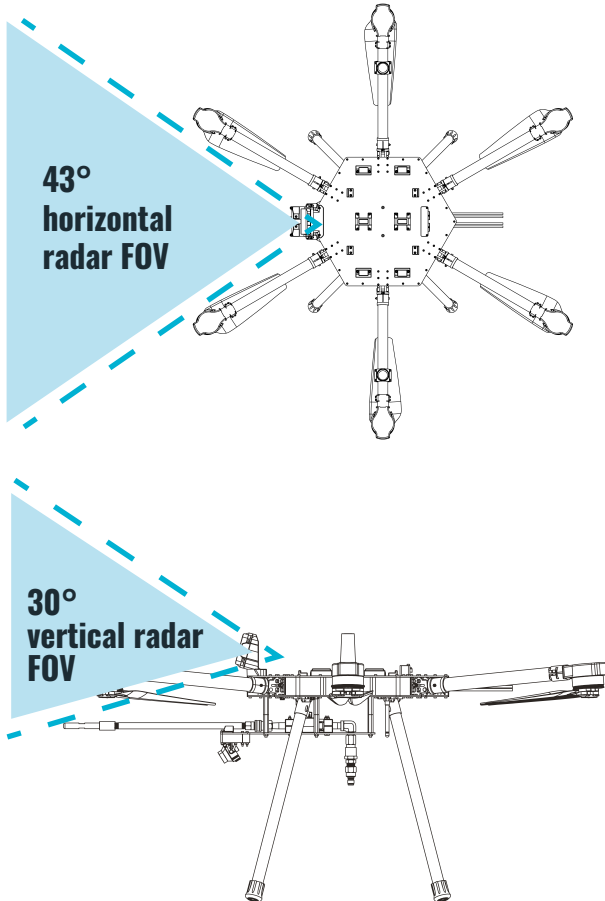

The collision prevention distance in the forward direction is 3m (~10ft).

The operator has the ability to turn collision prevention on/off using the “B” button on the controller.

Visual Indicators:

- **RADAR ON:** “B” button on controller is NOT illuminated and distance bars are present on FPV screen as the drone approaches obstacles
- **RADAR OFF:** “B” button on controller is illuminated and distance bars are NOT present on FPV screen as the drone approaches obstacles

If the RPIC attempts to arm the drone while the radar is disengaged, they will receive an on-screen notification stating that the radar is inactive and arming will be prevented.



**THE RADAR MUST BE ENGAGED TO ARM THE DRONE. IF THE RPIC WISHES TO MANUALLY DISABLE THE RADAR AFTER TAKEOFF, THEY MAY DO SO. THE OPERATOR ASSUMES ALL LIABILITY FOR COLLISION IF THEY ELECT TO DISABLE COLLISION PREVENTION AFTER TAKE-OFF. PLEASE FLY WITH CAUTION.**

### Important Notes about Radar Performance:

- The use of non Lucid-supplied nozzles and non-standard spray tips may be detected by the radar and interpreted by the drone as an obstacle. If this occurs, the operator will struggle to move the drone in a forward direction and/or the drone will appear “twitchy” when traveling in a forward direction.
- High winds that cause a high volume of spray blow-back can occasionally be detected by the radar and interpreted by the drone as an obstacle. This can happen intermittently when using an upward-facing nozzle.
- Not all small, thin objects can be detected by the radar. For example, guy-wires, small tree branches, and smaller power lines may not be large enough to register as an object and a collision may not be prevented.



**WARNING: THE COLLISION PREVENTION SYSTEM WILL ONLY PREVENT CONTINUED MOVEMENT IN THE FORWARD DIRECTION IF THE DRONE POINTED TOWARDS THE OBSTACLE IN THE FORWARD DIRECTION. IF THE RPIC NAVIGATES THE DRONE LATERALLY (SIDWAYS) WITHIN 10FT OF THE BUILDING, THEN YAWS TO FACE THE BUILDING, THE DRONE WILL NOT BE “PUSHED BACK” FROM THE BUILDING. IF THIS OCCURS, THE PILOT SHOULD NAVIGATE THE DRONE BACKWARDS OUTSIDE OF 10FT, THEN ADVANCE TOWARDS THE BUILDING UNTIL THE DRONE REACHES THE 10FT COLLISION PREVENTION DISTANCE.**



**Note:** The colored bars may not accurately represent distance to obstacles. In some cases, objects such as nozzle tip or spray stream may cause the display bars on-screen to falsely represent distance to (true) obstacles. The radar will still prevent collision with large objects such as buildings in the forward direction despite this on-screen display discrepancy.

# Failsafes

## Emergency Stop Function

The operator can command the motors to stop at any time during flight if deemed necessary for safety reasons.



**EMERGENCY STOP IS TRIGGERED WHEN THE TWO BLACK "ROLLER DIALS" ON THE TOP OF THE CONTROLLER LABELED "EMERGENCY STOP" ARE BOTH ROLLED OUTWARD MORE THAN 75% OF THE TOTAL ALLOWABLE DISTANCE. THE ROLLERS ARE POSITIONED SUCH THAT THEY ARE ACCESSIBLE TO THE OPERATORS' INDEX FINGERS.**



**WARNING: USING THIS FUNCTION TERMINATES FLIGHT BY STOPPING ALL MOTORS. WHEN MOTORS STOP, THE DRONE WILL FALL FROM THE SKY.**

**Note:** This function is ONLY intended to be used in emergency situations and SHOULD be used in emergency situations. It is not intended to be used during day-to-day operations in place of disarming.

## Auto-Disarm

Drone automatically disarms after ten (10) seconds if the drone was armed but never left the ground.

### Why is this important?

It is never a good idea to let a drone sit on the ground with propellers spinning for any extended period of time. Even though the drone has not left the ground, the propellers are providing some lift. Small gusts of wind can cause the drone to "tip over" if propellers are spinning for extended periods while on the ground.

### How to operate safely:

Only arm the drone once you are ready to take off and fly.

## Reflect New Compass Release

The drone determines that it cannot receive data from enough satellites and is not confident enough in its position to allow for safe operations.

### What is an RTK fix?

An RTK fix is a technical term used to represent highly accurate GNSS positioning and/or a method used to determine heading using satellites and multiple antennas.

### What can cause this?

- If either of the two antennas on each arm become damaged
- Large objects or other electronics are blocking reception
  - › **Example:** If the controller is resting on top of the drone while not in use
  - › A person is standing over the drone blocking antennas from seeing satellites
- Trying to operate in an "urban canyon" with one or multiple tall buildings blocking clear view of sky
- Close proximity to high voltage power lines and/or RF equipment
- Additional (non-Lucid) aftermarket electronics added to platform
  - › **Example:** GoPro camera
  - › Devices using USB-3 should never be used on a drone and are known sources of strong interference

## RC Loss Failsafe

The drone determines that it is no longer connected to and/or communicating with the controller.

### What could cause this?

- Operator ignores controller low-battery warnings and controller battery dies mid-flight
- Controller overheats from long-term direct sun exposure
- Antennas on controller or drone are damaged
- Drone operates outside of controller range and/or line-of-site

### How to prevent this from happening:

- Charge controller overnight before beginning projects
- Keep controller in shady areas when not in use to prevent overheating, particularly on hot days

### What does the drone do when this happens?

- The drone will enter Hold Mode
  - › The drone will hover in place until the operator regains connection. If the operator is unable to regain connection, the drone will continue to hover in place until the critical battery failsafe triggers an automated landing

## Flip Detection Auto-Shutoff

Drone detects that it has flipped over and automatically stops motors.

### What could cause this?

- If a propeller with incorrect orientation is installed on the wrong motor, the drone will flip during takeoff
- The operator collided with an object causing the drone to tilt beyond allowable flight limits

### How does it work?

- If the drone determines that it has tilted more than 60 degrees during flight, this is classified as a "flip" and the motors will shut off
- During normal operation, the drone is configured to limit tilt and will not exceed 45 degrees



**IMPORTANT: THE PROPELLERS PROVIDED AND INSTALLED BY LUCID HAVE BEEN ASSEMBLED TO MATCH INVERTED MOTORS ON THE SHERPA. DO NOT INSTALL ANY PROPELLER FROM A VENDOR OTHER THAN LUCID. PROPELLERS PURCHASED AND INSTALLED FROM MOST ONLINE (NON-LUCID) VENDORS WILL NOT BE THE CORRECT ORIENTATION AND WILL ALWAYS RESULT IN A FLIP/CRASH ON TAKEOFF.**

## Motor ESC Not Detected

The drone determines that it cannot communicate with one or more motors.

If a motor is continuously chirping upon startup, DO NOT FLY.

### What happens?

If the drone cannot communicate with one or more motors, you will hear a "chirp" coming from the suspect motor(s).

### What could cause this?

- A minor (or major) crash/collision
- Pinched or damaged wires at arm hinges
- Aggressive product handling and/or mishandling during shipping that causes wires to become dislodged from connectors

## Aftermarket Nozzles

- Lucid understands that many operators wish to use other nozzles, spray patterns and/or may attempt installing a longer nozzle on the drone
- Lucid strongly discourages the installation of any nozzle that is not supplied by Lucid. Installation of an improperly balanced nozzle can result in high vibrations and/or a load imbalance and lead to unexpected/undesirable flight behavior and/or result in a crash and voided warranty
- Do not daisy-chain nozzles to extend their length



**ATTEMPTING TO MODIFY AND/OR EXTEND THE NOZZLE OF THE DRONE MAY RESULT IN A CRASH!**

## Aftermarket Hardware

Lucid strongly advises against attaching third-party hardware such as GoPros or lights to the drone. Any unapproved hardware has the potential to cause high interference, degrade sensor performance, and cause excessive vibrations and/or weight distribution issues. If you have an idea for an attachment or accessory you would like to try, please contact Lucid. We would love to learn more about your request!

**Note:** If you apply for and receive an FAA Part 107 waiver for night operations, please contact Lucid for more information regarding placement of small strobe lights.

## Flying with Hose Attached

Flying the Lucid Sherpa Drone with the hose attached may feel different for the pilot from flying the drone without the hose. The pilot must maintain awareness of hose tension and/or obstacles that may restrict the drone's movement. Always allow for free movement of the hose. Additionally, Lucid recommends that the pilot lay out excess length of hose under the drone before takeoff to prevent hose tension immediately after takeoff.

The pilot assistant should constantly check the hose to allow for enough slack in the hose. This helps to prevent the drone from working too hard and using too much battery power. The drone will have drastically reduced flight times if hose management is not executed properly throughout the flight.

The pilot and pilot assistant should attempt to lay out the hose to match the spraying/rinsing flight pattern of choice.

## Hose Clamps

Lucid does NOT recommend using standard hose clamps to secure the quick connect fitting to the hose that supplies water/cleaning solution to the drone. Operators who use hose clamps are likely to experience blowouts when the hose is under tension, at height and/or as pressure builds in the hose with the valve closed. Instead, Lucid recommends using compression fittings.

## Compression Fittings

Compression fittings are the recommended method of securing fittings to hoses carried by the Lucid Sherpa. Compression fittings reduce the chance of hose blowouts that can occur

when the spray valve is closed and line pressure builds. When using flexzilla hose, we recommend using Flexzilla brand compression fittings compatible with the hose diameter of your choice.  $\frac{3}{8}$ " Flexzilla hose is the recommended hose diameter.

## Relieving Hose Pressure

- It is important to remember that after a flight, even if the pump is no longer running, there could still be residual pressure in the hose supplying water and chemical to the drone
- Do not remove the hose from the drone while still under pressure to prevent getting sprayed with water and/or chemical
- To prevent this from happening, once the drone has landed, follow these steps:
  1. Land the drone but make sure not to unplug the batteries immediately
  2. Turn off the pump
  3. Move the slider on the controller to "Land" mode to prevent accidental arming
  4. Position the drone in an area that will not be negatively impacted from turning on the nozzle while on the ground
  5. Toggle the spray switch to the "ON" position
  6. Wait until the stream is no longer under pressure and flows slowly out of the nozzle
  7. Remove hose

Alternatively, some operators elect to install a small in-line ball valve that allows them to shut off water at the end of the hose. This provides operators the ability to "hot swap" the hose to another drone or softwash gun while the pump is still running.

## Ports on the Underside of Fuselage

There are 6 ports on the underside of the drone's fuselage:

1. Servo
2. RC Antenna
3. FPV Camera
4. Radar
5. RC Antenna
6. Injector Valve (Window Washing Payload)

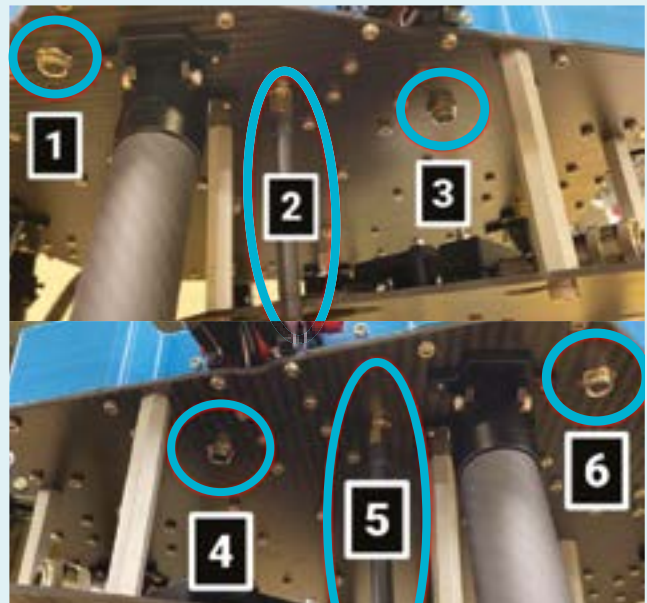

**Please contact Lucid for detailed information about repairs or component replacement.**

## Landing Protocols

To land the drone, the pilot either returns to the takeoff area or lands in another predetermined landing zone, ensuring all safety protocols have been met. Upon entering the landing zone, command the drone to descend as slowly and consistently as possible to land the aircraft.

When landing, ensure that the drone is free of obstructions and other obstacles. Ensure that the hose does not stack on itself in a manner that may interfere with landing; reposition hose as needed. Once the drone has landed, continue to hold the throttle fully down until the propellers stop spinning and the drone disarms.

In rare cases, landing on uneven terrain may cause a delay in disarming. Always land on even terrain to ensure safe landing and disarming.

## Landing Procedure

1. Approach designated landing zone, keeping drone's orientation identical to pilot's orientation
2. Begin descending aircraft slowly and consistently
3. When flying with hose attached to drone, pilot may need to roll aircraft back and forth to lay out hose
4. As the drone approaches ground (<5' altitude), ensure hose is not bunched up beneath the drone
5. Once the drone has touched down, hold the throttle stick (left stick) all the way down
6. Continue to hold the throttle stick all the way down until the motors will stop spinning and the drone disarms
7. After the drone has landed, and motors have stopped spinning, unplug both batteries to turn the drone off

## Transporting the Drone

The Lucid Sherpa Drone case is approximately 24 cubic inches in volume and waterproof. Lucid recommends storing the drone in the case between projects to prevent damage during transit.

NEVER transport the drone with chemicals present on the surface of the airframe. Always clean the drone and allow it to completely dry before storing in the case.

Do not place loose items in the case with the drone. During transport, loose items may shift and cause damage to the drone.

## Window Washing Payload



**DO NOT EXCEED 500 PSI WHEN USING WINDOW WASHING PAYLOAD.**

Do not use Lucid Clear in combination with other chemicals such as sodium hypochlorite. Violent chemical reactions and/or toxic gasses may result from incompatible chemical mixtures.

### Best Practices

Land mode may be used by the pilot at any time to conduct an automated landing. Land mode is also used during some failsafe conditions if the onboard sensors and logic determine that a controlled landing is needed for safety reasons.

1. Do not clean windows in direct sunlight to prevent rapid evaporation. Cleaning hot windows in direct sunlight will result in cleaning solution drying on the window. Once chemical dries on a window, it becomes extremely difficult to remove.

1. Early mornings are the best time to clean windows.

2. Always work on the shaded side of the building and avoid cleaning windows exposed to direct sunlight.

2. Water → Cleaning Solution → Water

1. It is best to first wet the window with deionized water, apply Lucid Clear, then rinse with deionized water again. Wetting windows before applying Lucid Clear enhances the cleaning power of the solution and cools down the window.

3. ONLY use clean, deionized water!

1. Make sure that your water is as clean as possible. Removing particulates from water is critical to ensuring a spot-free rinse.

2. Use a TDS meter to verify water cleanliness before use. <10ppm is generally considered an acceptable particulate level for window cleaning.

1. Do not use a dirty tank.
2. Do not use a dirty hose.
3. Do not use a dirty nozzle.
4. Do not use a dirty pump.
5. When possible, use deionized water with a dedicated hose and pump for water and water only. If you previously sprayed other chemicals or dirty water through a hose or pump, results may vary.

4. DO NOT ALLOW ANY CLEANING SOLUTION TO DRY ON THE WINDOWS

1. For best results, the dwell time of Lucid Clear should be two (2) minutes on each window.

5. Rinse from the top down!

6. Spend extra time on window frames. Dirt, dust, debris, and excess cleaning solution can aggregate on these surfaces and may run down onto windows after cleaning or during the next rain event.

7. Ground test the equipment you plan to use with the window washing payload to make sure it works as intended once you're up in the air.

## Operating Limitations

1. The injector valve may reduce flow rate. Using a low flow rate pump may not provide adequate flow for the injector to draw solution from the onboard tank.
2. Nozzles with smaller orifices restrict flow. Some nozzles may not provide adequate flow for the injector to draw solution from the onboard tank.
3. The window washing payload has a max pressure rating of 500 PSI. Using higher pressure will damage the injector.
4. Using different nozzles might change your dilution ratios slightly.
5. Empty and clean the window payload tank when storing or shipping the drone.

**NOTE:** Chemical injection increases with pressure. If the RPIC attempts to arm the drone while the radar is disengaged, they will receive an on-screen notification stating that the radar is inactive and arming will be prevented.

## Dilution Ratios

Flow Rate (GPM)	3.7GPM @ 100 PSI	5.3GPM @ 200 PSI	11GPM @ 300 PSI (Pump Output)
Outlet Pressure	45 PSI	90 PSI	7.5 GPM @ 250 PSI (At Nozzle)
Nozzle Size	0.125"	0.125"	0.75"

Metering Tip Color	Dilution Ratio	Dilution Ratio	Dilution Ratio
Copper	1:945	1:1141	1:3704
Pumpkin	1:787	1:878	1:2265
Burgundy	1:630	1:777	1:1999
Lime	1:473	1:601	1:1544
Tan	1:426	1:545	1:1402
Orange	1:270	1:405	1:1042
Turquoise	1:269	1:404	1:1040
Pink	1:171	1:229	1:584
Light Blue	1:148	1:182	1:464
Brown	1:125	1:172	1:441
Red	1:102	1:132	1:337
White	1:79	1:114	1:292
Green	1:65	1:103	1:263

Blue	1:51	1:75	1:191
Yellow	1:39	1:51	1:131
Black	1:27	1:40	1:101
Purple	1:19	1:19	1:38
Gray	1:11	1:15	1:29
No Tip	1:8	1:9.5	1:19.5

\*The final dilution ratio is calculated based on using a softwash pump that is rated for 11 GPM at 300 PSI attached to 250' of ½" flexzilla air hose with 140' of it in the air with our straight nozzle attached which brings our flow rate down to 7.5 GPM at the drone. We can assume that at least 50 PSI is lost due to hose length and other components on the payload.

## Personnel

### Pre-Flight Roles and Responsibilities

It is the responsibility of the Remote Pilot in Command (RPIC) to complete the required pre-flight procedures and checklist **PRIOR** to every flight.

### Remote Pilot in Command (RPIC)

Remote Pilot in Command (RPIC) is responsible for all aspects of the drone operation. Lucid recommends that the RPIC perform the following:

1. Familiarize themselves with this User Manual.
2. Refrain from deviating from the manual unless necessary to ensure the safety of the operation and the personnel.
3. If the RPIC encounters a problem not addressed in the manual, suspend operations and contact the Lucid support team.
4. The RPIC should always use his/her better judgment to determine whether a safe operation is plausible.

### Pilot Assistant / Visual Observer (PA/VO)

A Pilot Assistant (PA) or Visual Observer (VO) is a crew member that aids the pilot before, during, and after the flight. The PA will help the pilot in command to determine potential obstacles in the flight path, monitor the operations area, keep pedestrians clear of the operations area, prevent hose snagging, prepare a pre-flight checklist, and help the pilot to notate proximity to objects.

The primary responsibility of the PA is to support the RPIC by monitoring the drone and hose during the flight. The PA is responsible for constantly surveying the operating area for obstructions, hazards, bystanders, inclement weather, other aircraft, and wildlife.

 **THE PA SHOULD NEVER STAND DIRECTLY BENEATH THE DRONE. THE PA SHOULD MAINTAIN A SAFE DISTANCE FROM THE AIRCRAFT WHILE IT IS IN FLIGHT.**

### Additional Crew

Frequently, large-scale operations may require additional crew members. Collectively, the RCIP, PA, and any additional crew members are referred to as the "Crew."

If the operation dictates a need for additional crew members, set up standard forms of communication to ensure effective communication while in flight. Crew members should be briefed prior to the operation. Crew members should be aware of their roles, responsibilities, and hierarchy in the operation.

## In-Field Troubleshooting

The Lucid Sherpa is equipped with LTE and comes included with a SIM card installed. When speaking to a Lucid customer success, please have your controller charged and powered on. Your drone must also be powered on for remote troubleshooting—only one battery is required to power the drone for support purposes.

### On-Screen Notifications

(ONLY) important notifications are displayed in a highly visible on-screen pop-up. Less important notifications will be found after clicking the top right icon (circled on following page). Typically, these less important notifications are only relevant for troubleshooting purposes.

If you receive a notification and are unsure as to whether it is safe to fly, please contact Lucid support.

All notifications, errors, and messages are logged and transmitted to Lucid staff in near real-time over LTE to aid in remote troubleshooting. Additionally, flight logs are stored internally on the drone and may be retrieved by Lucid staff in the event that they cannot be transmitted over LTE.



## Notifications

Important notifications (only) are displayed in a highly visible popup. Where possible notifications include both the cause of a problem and any actions that should be taken.

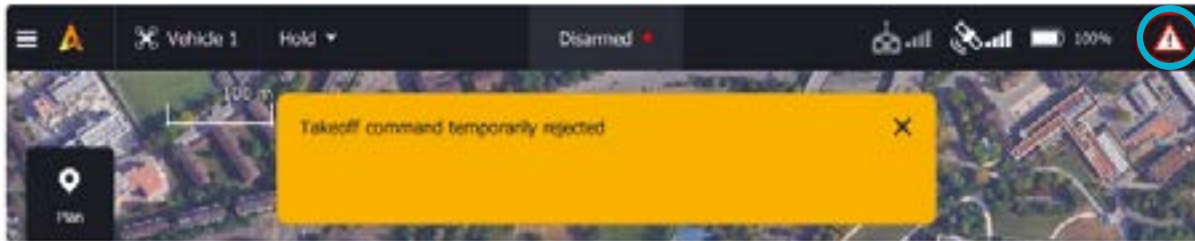

Less important notifications are [logged](#).

## On-Screen Messages, Errors, and Notifications

Message Type	Description	What to Do
RC Not Neutral	When arming, the RC sticks were not in a safe position to arm the drone. Typically this means that both sticks were used when arming.	Only the left joystick is required to arm the drone. The right joystick should remain in the center position when arming.
Mode Not Armable	The drone's flight mode does not allow for safe arming. Typically this means the drone is in "Land mode".	Toggle the slider in the center of the controller to "Position" mode. If already in position mode, toggle into "Land" and then back into "Position".
RTK Errors	The GNSS antennas are unable to receive a strong enough signal from satellites to compute the drone's heading.	Move the drone to a position free from large buildings or nearby obstructions to acquire an RTK fix.
EKF Errors	The algorithms governing stable flight have detected an anomaly.	Move the drone to level ground with a clear view of the sky, restart the drone and let the drone initialize again.
Proximity Errors	The forward-facing collision prevention system is detecting a nearby object before takeoff.	Reposition the drone further away from objects such that the forward-facing radar does not detect a nearby object.
Radar Errors	This message displays when the forward-facing collision prevention system is inactive (off) when arming.	Radar must be engaged to arm the drone. Radar can only be disengaged after takeoff.
GPS Errors	An anomaly is detected in the drone's calculated position.	Power down the drone and restart. Ensure drone is sitting still during initialization and has clear view of the sky.
Compass Errors	An anomaly with compass heading was detected by more than 20 degrees.	Move the drone away from large metal objects and restart the drone.
Battery Messages	The pilot will receive a series of on-screen messages indicating low, critical and emergency battery levels.	Upon receiving the first low battery warning, the pilot should begin finding a safe landing location.
Spray Won't Turn On/Off	The RPIC unable to control on/off function of sprayer.	With drone powered on and in land mode, toggle spray switch. Listen for servo movement. If the servo is attempting to move (indicated by audible feedback) but appears stuck, manually attempt to move the ball valve to break away any corrosion that may be preventing full range of motion.



# Sherpa Maintenance Guide

It is the responsibility of the RPIC to inspect the drone for any visible damage before each flight.

## Airframe Inspections

### Drone Body

- Check for cracks or damage along all six carbon fiber arms.
- Check for cracks or damage on the drone's landing gear and brackets supporting the landing gear.
- Check that all bolts are present and fully tightened.
- Check each landing gear leg to ensure they are tight and cannot be moved easily by hand. Over time, it may become necessary to tighten the bolts on the bracket(s) that secure the leg(s) to the fuselage.

### Motor Inspection

- Check that the motors are level with respect to the body of the drone.
- Check that the motors are not making any unusual whine or scraping sounds while in operation.
- With the drone powered off, turn each motor by hand to test corrosion damage. All motors should spin freely and quietly. A problematic motor will sound different than the others and/or be more difficult to turn than other motors.

### Propeller Inspection

- Check that propellers are not cracked or warped in any fashion. If you notice that one of your propellers is damaged, replace with a propeller of the corresponding direction (clockwise or counter-clockwise) found in your Customer Repair Kit.
- If you need to replace a propeller, double check that the direction of the propeller correspond appropriately with the motor. If the propeller does not match the motor direction the drone will crash.

See Drone Systems and Components -> Motor and Propeller Direction in this User Manual for more information on installing replacement propellers.

### Lithium Battery Inspection



**IF ANY OF THE FOLLOWING ISSUES ARE DISCOVERED IN BETWEEN RECOMMENDED MAINTENANCE PERIODS DO NOT FLY WITH THE BATTERY IN QUESTION.**

- All sides of the battery should be flat and should not appear inflated, ballooned, or puffy.
- Check battery connectors for corrosion or physical damage.
- The battery should not be excessively hot to the touch while charging or after use. Some warmth is expected during charging/use.
- Battery cell voltages should be balanced within 0.5V of all other cells on the battery. If the cells are not balanced, perform the discharge task on your Lucid Battery Charger until the cells are balanced and then recharge the battery. This may take several hours.

### Wiring Inspection

- Inspect power cables protruding from the rear of the drone for any signs of damage.
- Inspect all visible wires for signs of damage to the wire jacket.
- Inspect wire port on the underside of the drone to ensure the connector is fully seated. Hand-tighten connectors as-needed.

## Drone Storage

Properly storing your drone will dramatically extend the lifespan of the product. Keep your drone in good condition by adhering to the following:

- Never store the drone in a case when water or chemical is still present.
- Allow the drone to dry before storing.
- Do not leave the drone inside of a high temperature location (such as a car or attic) for extended periods of time.
- Check to ensure no liquids pool inside the case.
- If excessive liquids are present inside the case, wipe down the inside.
- Never leave the lid to the case closed while liquids are present in the case to prevent humidity buildup.
- Do not store the drone outside of the case in coastal environments. Salt air will cause rapid corrosion of drones and other equipment.
- Never store the drone with chemical or liquid present in the window washing payload (if installed).
- Do not store wet rags used to wipe down the drone inside the case.
- Do not store drone batteries inside drone case. Always store batteries separately in fire-resistant LiPO-safe bags.

## Maintenance Schedule

We have developed the following maintenance schedule as a guide to help pilots to maintain the aircraft and keep the Sherpa in peak operating condition.

The most important thing you can do to extend the life of your drone is to perform routine maintenance.



**THE #1 CAUSE OF EQUIPMENT FAILURE IS CORROSION DUE TO LACK OF ROUTINE MAINTENANCE.**

The maintenance schedule is broken down by drone operating hours:

### After Each Use

1. Flush the inside of each motor using a garden hose for thirty (30) seconds each.
2. Flush the quick connect ports (nozzle and hose inlet) with fresh water.

- Using low pressure, spray down the fuselage with fresh water.
- Use a rag to remove any excess water or chemical from the drone frame.



**IMPORTANT: DO NOT USE HIGH PRESSURE TO CLEAN THE DRONE. THE PRESSURE AND FLOW FROM A GARDEN HOSE IS SUFFICIENT.**



**IMPORTANT: DO NOT SPRAY DIRECTLY INTO ARM HINGES WHERE WIRES ENTER THE FUSELAGE OF THE DRONE.**

### Every TEN FLIGHT Hours

- Perform airframe inspection
- Check propeller tightness
- Check for loose arms
- Check hose nozzle connection
- Spin motors and props to ensure they are clear of debris
- Tighten landing gear bolts
- Tighten folding arm mount bolts
- Clean the drone thoroughly

### Every FIFTY FLIGHT Hours

- Perform airframe inspection
  - Check frame arm locks for wear
  - Check motor arms to ensure they are still tight
- Turn on aircraft and check for abnormal noise
- Check payload plate; tighten nuts/bolts if necessary
- Make sure battery connections are clean
- Tighten any bolts that seem loose
- Apply (non-permanent) thread locker to any bolts that need it
- Check motor bases for cracks or damage
- Ensure arms lock in place at the correct altitude
- Check landing gear bracket bolts; tighten if necessary
- Spin motors and propellers; ensure they spin freely
- Confirm the remote controller is working properly and check for damage
- Check remote controller antennas and threads for damage
- Flush motors with fresh water to ensure motors are free of debris

### Every ONE HUNDRED FLIGHT Hours

- Perform airframe inspection
  - Check upper and lower plates for cracks and damage
  - If cracks/damage exist, call Lucid for additional support
- Check frame arm locks for wear

- Check motor arms to ensure still tight and not loose
- Turn on aircraft and check for abnormal noise
- Check payload plate; tighten bolts if necessary
- Check cables; do not move them aggressively
- Tighten any bolts that seem loose
- Apply thread locker to any bolts that need it
- Check motor bases for cracks or damage
- Ensure arms lock in place at the correct altitude
- Check landing gear bolts; tighten if necessary
- Spin motors and propellers to ensure they spin freely
- Confirm the remote controller is working properly and check for damage
- Check remote controller antennas for damage
- Spray motors with fresh water to ensure motors are free of debris
- TAKE PROPS OFF MOTORS
- Arm the motors and monitor for abnormal sounds
- REPLACE THE PROPELLERS AND DO NOT INSTALL OLD PROPELLERS
- Check battery cables for abrasions

### ONE-YEAR Maintenance

- Perform the one hundred (100) flight Hour inspections above
- Inspect and/or replace all propellers
- Inspect all motors and ship drone to Lucid for motor replacement. (replacement by others is not recommended)
- Inspect and/or replace spray servo
- Inspect and/or replace window wash payload solenoid

### TWO-YEAR Maintenance

After owning the drone for a period of two (2) years, conduct the following:

- Conduct a one hundred (100) hour maintenance inspection
- Replace all propellers
- Inspect all batteries
  - Although batteries last up to 100 cycles, Lucid recommends replacing the batteries after 2 years, no matter the usage frequency
  - Renew Part 107 Certificate with the FAA

### Bleach Neutralizer

Bleach neutralizers can be an effective means of stopping the corrosive action of sodium hypochlorite on many equipment types and can be helpful to include in your maintenance routine.



**A FRESH WATER RINSE/FLUSH IS STILL REQUIRED AFTER USING BLEACH NEUTRALIZER. BLEACH NEUTRALIZER DOES NOT REPLACE A FRESH WATER RINSE/FLUSH.**

## Component Spec Sheets

---

### Tattu Lipo Battery Guide

<https://genstattu.com/bw/>

### Tattu Plus 1.0 Compact Version 10000mAh 44.4V 15C 12S1P Lipo Smart Battery Pack

<https://www.genstattu.com/content/TAA16KP12S15X.pdf>

### ISDT X16 Battery Charger

<https://www.isdt.co/download/pdf/X16.pdf>

### DEMA 311.125 Rocket Injector

<https://www.demaeng.com/wp-content/uploads/2020/12/RocketTechnicalGuide.pdf>

### SIYI MK15 Controller

[https://www.foxtechfpv.com/product/radio-control/MK15/MK15\\_User\\_Manual\\_en\\_v1.1-210824.pdf](https://www.foxtechfpv.com/product/radio-control/MK15/MK15_User_Manual_en_v1.1-210824.pdf)

### Auterion Software

<https://docs.auterion.com/operators/getting-started/readme>

### Lucid Clear SDS Sheet

<https://luciddronetech.com/knowledge/lucid-clear-sds-sheet>

## Customer Success

---

### Knowledge Base and Helpful Resources

Visit our Knowledge Base for Quick Start Guides, How Tos, and Tips and Tricks at:

<https://luciddronetech.com/knowledge>

### Request Service or Repair

Submit a service request online at:

<https://luciddronetech.com/support>

## Contact Lucid

---

Contact Customer Support:

[support@luciddronetech.com](mailto:support@luciddronetech.com)

### Product Specifications

[https://docs.google.com/spreadsheets/d/1V-mn5O36oXBBukixLejGlqUyGF3\\_XqMuJB3era7Bfz0/edit#gid=0](https://docs.google.com/spreadsheets/d/1V-mn5O36oXBBukixLejGlqUyGF3_XqMuJB3era7Bfz0/edit#gid=0)

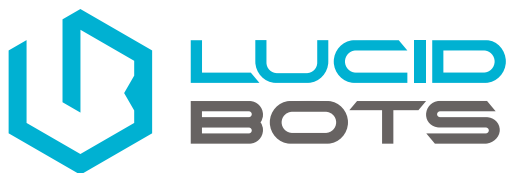

# Thank You

---

Visit us at:  [lucidbots.com](https://lucidbots.com)

**Enjoy taking flight with your Lucid Sherpa Drone!**

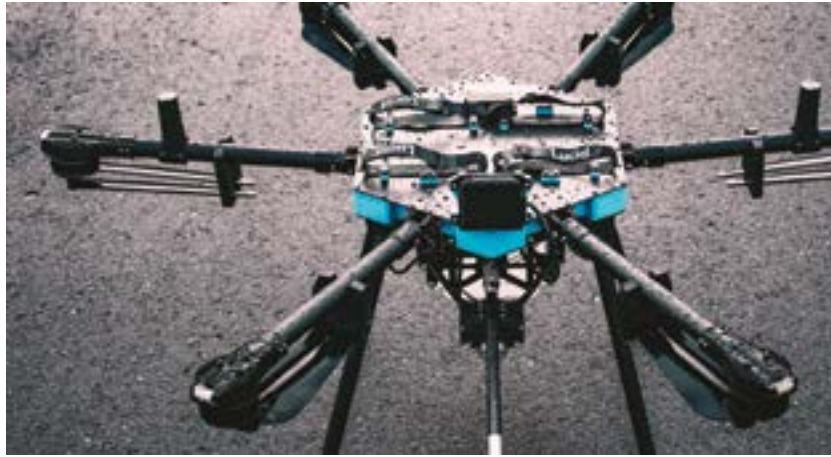
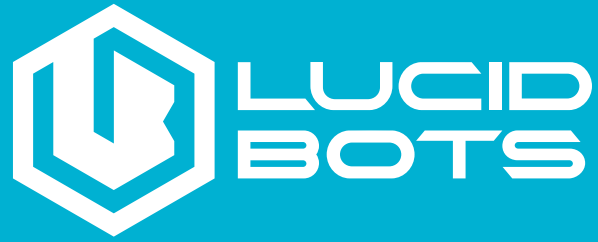

Follow us on social media   

 [lucidbots.com](http://lucidbots.com)